

# VanWeigh Lite®

Installation, Setup and Calibration Manual



[vpgonboard.com](http://vpgonboard.com)

**VPG**  
**ONBOARD**  
**WEIGHING**



## Important installation information and liability waiver

VPG designs and manufactures on-board vehicle weighing equipment. These installation guidelines are provided solely for the use of trained installers and represent the correct, safe and recommended method of installation.

These guidelines must be followed fully to ensure proper, safe installation. Failure to do so may result in serious consequences including, but not limited to, failure of the system to function properly and damage to the weighing equipment that could jeopardize the stability and safety of the vehicle.

VPG accepts no responsibility or liability for consequences arising from any improper installation of the weighing equipment including but not limited to, any misapplication or misinterpretation of the installation information contained herein.

Strict observance of these guidelines should help to ensure accurate weight measurement and enable safe operation of the vehicle. Failure of our on-board vehicle weighing equipment due to poor installation workmanship or incorrectly installed elements remains solely the responsibility of the installer.

VPG does not accept responsibility for the structural integrity of the vehicle concerned, for any part thereof, and for its proper, safe operation.

The company also reserves the right to make any amendments and alterations to this document deemed necessary. You should ensure you have the current version of this information by contacting VPG prior to performing installation, such as on our website at [www.vpgsensors.com](http://www.vpgsensors.com)



## Contents

Important installation information and liability waiver.....	3
Introduction and scope .....	6
Scope.....	6
About this document .....	6
Document Control .....	6
<b>Installation.....</b>	<b>9</b>
Components .....	10
Tools .....	15
Installation overview .....	16
Typical system schematics .....	18
How to install the power cable .....	19
How to install the ECU .....	20
Connecting the cables.....	21
Sensor types.....	22
Sensor installation positions .....	23
Axle transducer on a front strut.....	24
Axle transducer on a leaf spring.....	25
Air pressure transducer.....	26
How to install a steel axle transducer .....	27
How to install an air pressure transducer .....	30
<b>System Overview.....</b>	<b>35</b>
VanWeigh Lite® Web App Overview.....	36
Connecting to the web app .....	36
Viewing the web app for the first time .....	38

Web app operation .....	39
Home Page .....	40
How to navigate the web app.....	41
Set Up menu .....	42
Editing Values .....	43
How to configure the user options.....	44
<b>Configuration .....</b>	<b>45</b>
The configuration menu .....	46
How to configure the weighing units .....	47
Vehicle configuration .....	48
How to configure the ECU.....	49
How to configure the alarms .....	51
How to configure stability .....	53
Weighing the Vehicle.....	55
How to calibrate the ECU.....	56
How to configure the PIN Numbers.....	58
<b>Diagnostics .....</b>	<b>59</b>
The diagnostics menu.....	60
<b>Appendix A.....</b>	<b>63</b>
System configuration table .....	64
<b>Appendix B.....</b>	<b>65</b>
VanWeigh Lite® Specification.....	66
<b>Appendix C.....</b>	<b>67</b>
Warning and Status Messages .....	68
Alarm Icons.....	71

## Introduction and scope

VanWeigh Lite® is an overload monitoring system for use on twin axle vehicles with mechanical or air suspension systems.

### Scope

This document is intended as a guide to the installation and commissioning of VanWeigh Lite®.

It covers two transducer types currently supported in a VanWeigh Lite® system:

- VanWeigh Lite® axle transducers. These measure suspension deflection on mechanical spring suspension systems
- Air pressure transducers. These measure changes to air pressure on air suspension systems

Different system configurations can be used to support different chassis types. The system can be configured to use either type of transducer and any combination of the two.

### About this document

Any display screenshots used in this document are intended as an illustration of the function being described. As such, any specific detail or settings shown will differ from one installation to another.

The documentation uses the following conventions:

**IMPORTANT.** These are important notes and appear inside a blue box

**CAUTION.** These notes warn of an operation that may cause damage to the VanWeigh Lite® system. These notes appear inside an orange border

**WARNING.** These notes warn of an operation that may cause injury to the installer. The note is highlighted in a yellow banner

## Document Control

Document Version:

v1.1

Date:

22 August 2023

Version Notes:

## Important installation information

**IMPORTANT.** Please read this installation guide completely to ensure that all instructions are fully understood before you install VanWeigh Lite®

To ensure a reliable and properly functioning system particular importance should be paid to the following:

- VanWeigh Lite® axle transducer installation. A suitable location for the transducer should be carefully identified and that location should then be prepared for the transducer to be attached. See “How to install a steel axle transducer” on page 27
- VanWeigh Lite® axle transducer orientation. Axle transducers must be mounted to the vehicle in the correct orientation. See “How to install a steel axle transducer” on page 27
- Accurate recording of sensor serial numbers in their sensor positions. It is recommended that you use the system configuration table to record this information and refer to it when you are configuring the system. See “System configuration table” on page 64





# Installation

## Components

Below is a list of components that can be used in a VanWeigh Lite® installation.

Check that you have all of the appropriate components for your installation before starting.

**IMPORTANT.** Images are for illustration purposes only. Later versions may differ.

### WiFi Enabled Mobile Device

A kit with a single Mobile Device may be supplied for the system.

This is an optional component. The user may supply their own mobile device.

Part No: 777846-KIT (Kit)

Part No: 777846 (Mobile Device)

Part No: 544116 (Power Supply)

Part No: VWLITE-MOUNT  
(Dashboard Mounting Unit)

Part No: DRG-107028 (Mobile  
Device Bracket)



### Axle Transducer

A single cable with a connector at one end and the axle transducer at the other

This is supplied for steel axle suspension systems.

A single transducer is supplied for each transducer position. See “Sensor installation positions” on page 23.

Bonding tape is supplied for each transducer

Part No: 238121



## Air Pressure Transducer

The parts for the air pressure transducer are supplied in a bag. A single air transducer is made up from a T-connector, a brass sensor fitting and two plastic air pipe fittings

This is supplied for air suspension systems

A single transducer is supplied for each transducer position. See “Sensor installation positions” on page 23.

Part No: 996210C (For air pipe outside diameter 8mm & 10mm)

Part No: 542549 (Air sensor only)



## Internal Domain Cable with Air Transducer Fitting

A single transducer cable is supplied for each air transducer position. See “Sensor installation positions” on page 23.

Part No: DRG-106001



**Electronic Control Unit (ECU)**

A single ECU is supplied for the rigid vehicle

Part No: 328121



**Internal Domain ECU Cable 3 way**

The cable is identified by the green ECU connector and 3 male internal domain cable connectors

Part No: DRG-106898



**External/Internal Domain ECU Cable 2 way**

A single external domain output cable is supplied for each ECU

The cable is identified by the brown ECU connector at one end and at the other end, one external domain cable connector and one male internal domain cable connector

Part No: DRG-106897



### System Power cable

A single system power cable is supplied for the system

The cable is identified by the external domain cable connector at one end

Part No: DRG-106124



### Cable Protector and Cable Ties

Cable protector is supplied and can be cut as required

Cable ties are also supplied

Part No: 493459



### Surface Cleaning Wipes

Part No: 995627



### Double Sided Bonding Tape

Part No: 995614





## Tools

Check that you have the following tools before starting an installation.

Tool	Check
Screwdriver set	
Hex driver set	
Torx driver set	
Socket set	
Multimeter	
Side cutters	
Drill set	
G-Clamp	
Spanner set (including 18 mm and 24 mm)	
Air pipe cutters	

## Installation overview

**WARNING.** Ensure the engine of the vehicle is off and the parking brake is applied before starting the installation

**IMPORTANT.** It is recommended that you use a mechanics pit inside a workshop to install the VanWeigh Lite<sup>®</sup> system

A mobile device is used to display sensor information once the system has been installed, configured and calibrated.

The mobile device is connected to the ECU via Wifi and the information is viewed in a web browser. The ECU is installed on the chassis of the vehicle and is connected to all four sensors on the vehicle. The sensors form the internal domain.

The sensors send information back to the ECU. The ECU then transmits information back to a mobile device. This is the external domain.

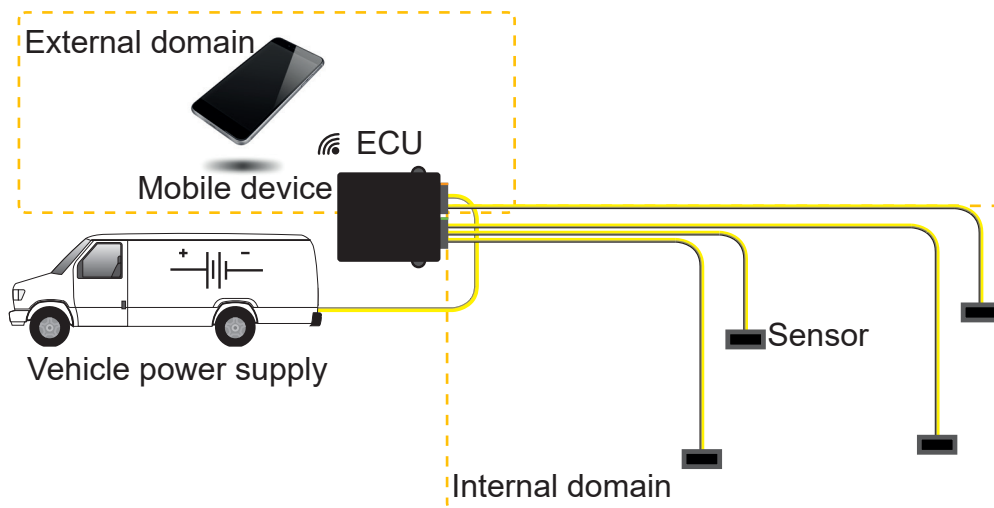

There are three main steps to installing the VanWeigh Lite® system:

- ECU installation. This must be installed on the chassis of the vehicle. It must be located in an appropriate position between the suspension systems and the cab of the vehicle. The external domain cable must be routed and connected to the vehicles power supply. The sensor cables must be able to reach the ECU.
- Sensor installation. The type of sensors you install will depend on the suspension systems in operation on the vehicle. Air pressure transducers are installed on air suspension systems. Axle transducers are installed on steel axle suspension systems. The sensors must be installed in an appropriate position on the suspension system and their cables must be routed back to the ECU.
- Mobile connection. The mobile device must be connected to the ECU over a Wifi connection.

**IMPORTANT.** It is recommended that the ECU is installed first, followed by the sensors and finally the mobile connection. However, these steps can be performed in any order.

## Typical system schematics

Below are two examples of system schematics showing where the ECU and transducers are fitted in relation to the vehicle. These are two example schematics, but a variety of configurations may be used.

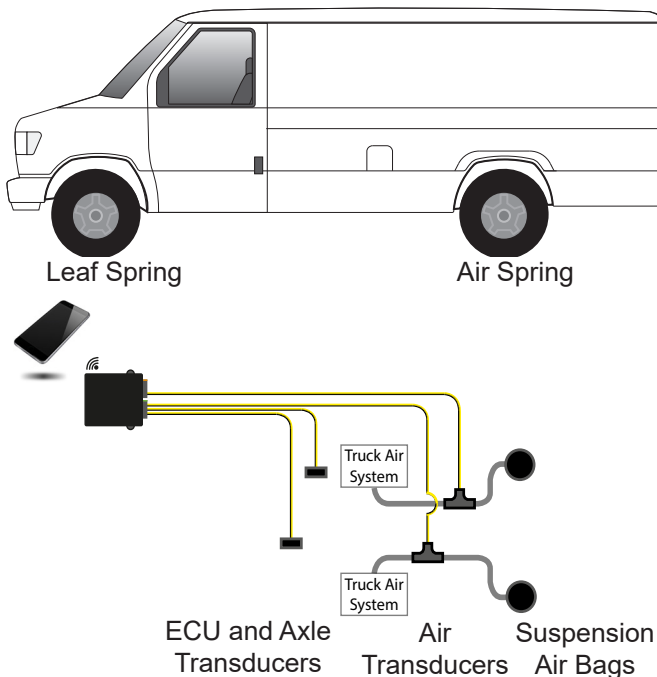
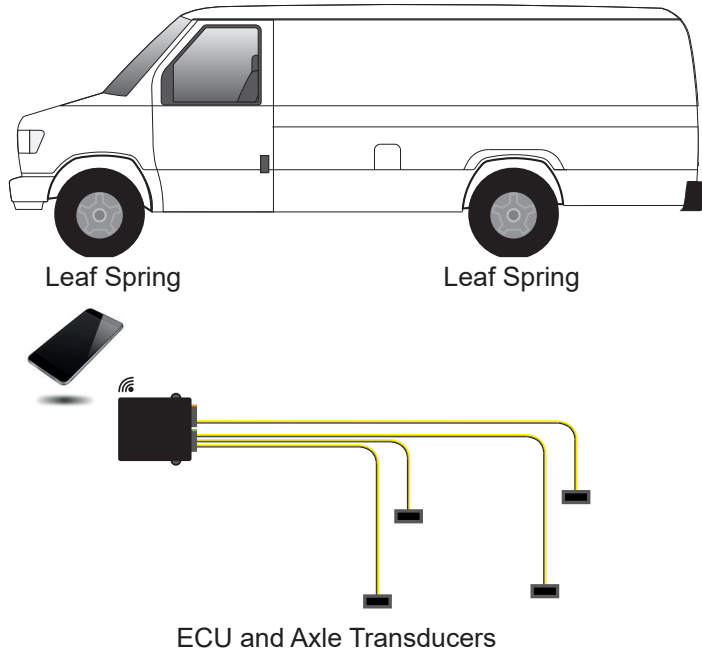

## How to install the power cable

A mobile device is used to display the sensor information. The ECU is installed on the chassis of the vehicle. The power cable is connected to the vehicle power supply and provides power for the mobile device and ECU:

1. Connect the power cable to the appropriate connection point for the power supply in the vehicle

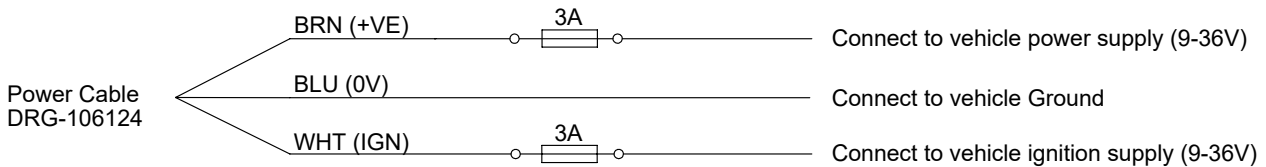

WIRING OPTIONS	+ VE	IGN.	0V	RESULT
1	BROWN	WHITE	BLUE	THE SYSTEM WILL TURN ON BY THE IGNITION KEY AND TURN OFF BY AUTO POWER OFF CONFIGURATION OPTION
2		BROWN & WHITE	BLUE	THE SYSTEM WILL TURN ON/OFF BY THE IGNITION KEY OR THE STAND BY ICON WHEN THE IGNITION IS ON

NOTE: THE MOBILE DEVICE CANNOT BE SWITCHED ON OR OFF BY THE IGNITION. MANUALLY SWITCH THE MOBILE DEVICE ON OR OFF AS REQUIRED.

- The system can be powered from 12V or 24V DC power supplies
  - The system has an operating range of 9V to 36V DC. Connect the white wire to the ignition to power the system on and off when the ignition is turned on or off.
2. Route the power cable from the vehicle power supply to the location of the ECU on the chassis of the vehicle.
    - Avoid running cables on or near sharp objects
    - Keep cables away from hot components such as exhausts and engines

**CAUTION.** Use cable protector to protect the cable at positions where it may be exposed to damage

**IMPORTANT.** It is recommended that you follow existing cable routes and ensure that the cable is able to plug into the rear of the display unit after it has been mounted

3. Test the power connection.

## How to install the ECU

A single ECU is used to receive information from each sensor in a suspension system.

### 1. Select a position to install the ECU where:

- The ECU cannot be damaged by any moving parts on the vehicle
- The cables from each sensor can reach the ECU. Ensure the cables can be routed from the transducer without risk of damage from any moving parts on the vehicle
- The power cable can reach from the vehicle power supply to the ECU. Ensure the cable can be routed to the vehicle power supply without risk of damage from any moving parts

### 2. Mount the ECU to the vehicle:

- The cable sockets must point to the rear of the vehicle

**IMPORTANT.** The VanWeigh Lite® system will not provide the correct measurements if the ECU is not mounted with the cable sockets pointing to the rear of the vehicle



- Use existing holes on the chassis to mount the ECU, if possible. Drill holes appropriate to the size and length of the mounting screws if existing holes are not suitable
- Use 2 X 1/4" or M6 screws with Nyloc nuts to mount the ECU. The length of the screws may vary depending on where you mount it

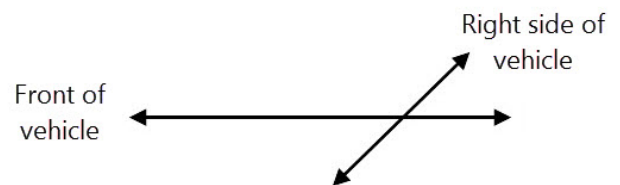

### 3. Make a note of the orientation of the top face of the ECU, e.g. facing up, down, left or right side of the vehicle. In the example shown above, the ECU is facing down

**IMPORTANT.** It is recommended that you use the system configuration table to record this information. See "System configuration table" on page 64



## Connecting the cables

The ECU has two ports. These are color coded to ensure that only the correct cables can be connected to the correct port:

- Port with green tab. This is the connection for the first three sensors. Sensor information is transmitted from the sensors to the ECU via this port.
- Port with brown tab. This is the connection for the fourth sensor and power. Sensor information is transmitted from the fourth sensor to the ECU via this port. Power is supplied to the display unit via this port.

1. Connect the three way sensor input cable to the green port on the ECU
2. Connect the two way sensor input and power connector cable to the brown port on the ECU

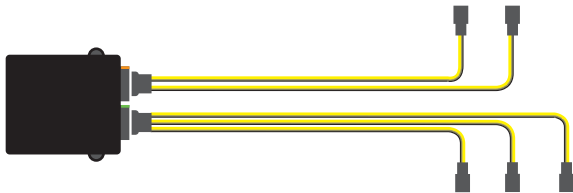

3. Connect the power cable from the vehicle power supply to the power connector

## Sensor types

Install the appropriate type of sensors on the suspension system of each wheel. There are two types of sensor:

- Axle transducer. This type of sensor can be mounted on steel axle suspension systems. This includes:
  - Front strut type suspension
  - Single axle leaf springs
- Air pressure transducer. This type of sensor can be mounted on air suspension systems

**IMPORTANT.** Air pressure transducers can only be used on air suspension systems that are self levelling.

## Sensor installation positions

The first step to sensor installation is to select the appropriate position to install each type of sensor on the vehicle.

**IMPORTANT.** Each sensor has a serial number. Make a note of the serial number of each sensor which you install, its position number and where it is installed on the vehicle. It is recommended that you use the system configuration table to record this information and refer to it when you are configuring the system. See “System configuration table” on page 64

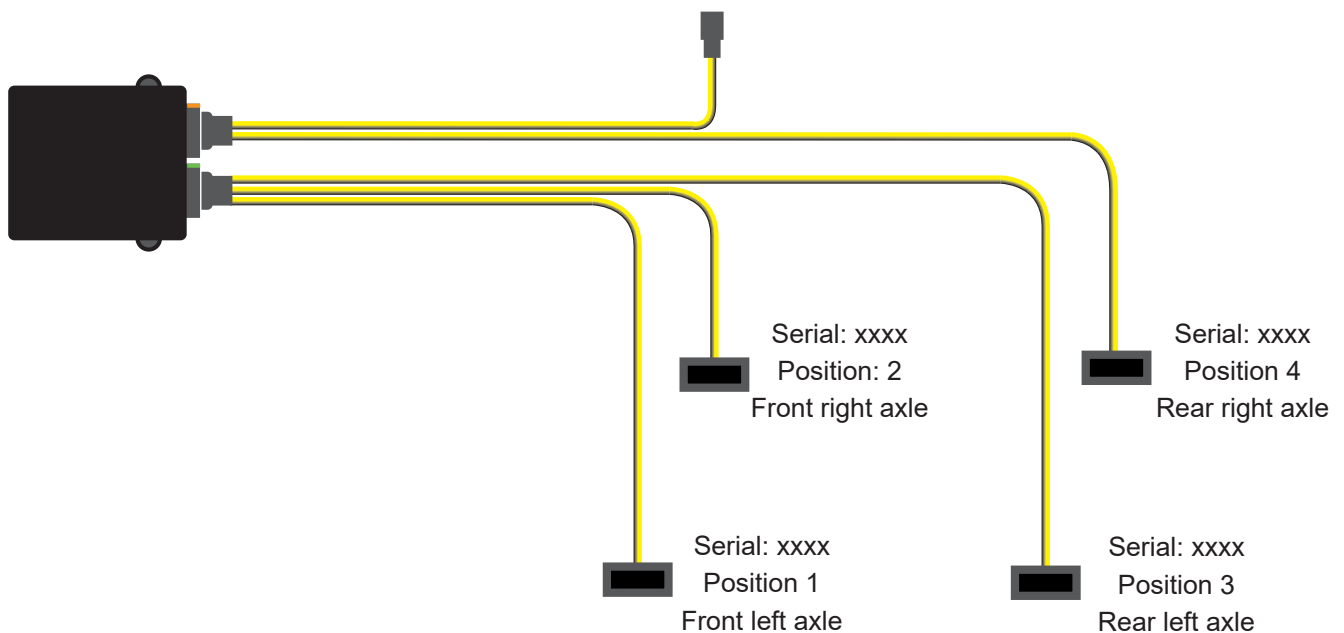

## Axle transducer on a front strut

Select a position to install the transducer on a front strut where:

- The transducer is perpendicular to the orientation of the chassis with the cable running away from the wheel
- The transducer is not at risk of damage from any part on the vehicle throughout the full range of movement of the strut
- The sensor cable can be routed to the ECU without risk of damage from any moving parts and allowing for the full range of movement of the transducer on the strut

**IMPORTANT.** When mounting the sensor, ensure it is in the correct orientation, with the groove at the top. See “How to install a steel axle transducer” on page 27 for further guidance



## Axle transducer on a leaf spring

Select a position to install the transducer on a single axle leaf spring where:

- The transducer is mounted to the top side of the spring
- The transducer is parallel to the orientation of the chassis
- The transducer is as far as possible from the axle. It can be mounted to the front or rear of the spring with the cable running away from the axle
- The transducer is not at risk of damage from any part on the vehicle throughout the full range of movement of the spring
- The cable can be routed to the ECU without risk of damage from any moving parts and allowing for the full range of movement of the transducer on the spring



**IMPORTANT.** When mounting the sensor, ensure it is in the correct orientation, with the groove at the top. See “How to install a steel axle transducer” on page 27 for further guidance

## Air pressure transducer

Select a position to install the transducer in an air circuit where:

- The transducer is between the self levelling valve and the air bellows
- The air transducer can be supported without risk of damage from any moving parts
- The cable can be routed to the ECU without risk of damage from any moving parts

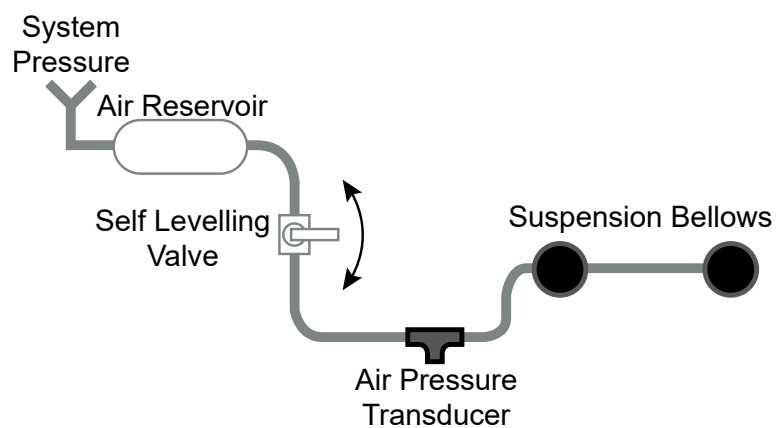



## How to install a steel axle transducer

A single axle transducer is used to monitor one side of an axle. In most cases, two axle transducers will be installed per axle, one on the suspension for the left wheel, one on the right.

**IMPORTANT.** Ensure that you select the appropriate position for the sensor. Please see “Sensor installation positions” on page 23 for guidance on selecting a position for a sensor

1. Clean and dry the surface where the transducer will be mounted to the suspension system:

- Use brake cleaner and scotchbrite to remove heavy debris
- Use alcohol wipes provided to ensure all grease is removed

**CAUTION.** Loose paint and rust must be removed. The site must be dry before installation

2. Ensure the mounting surface is at an appropriate temperature:

- The ideal temperature of the mounting surface is 70°F / 21°C
- If required, warm the spring with a hot air gun before bonding the transducer

**CAUTION.** It is not recommended to apply the bonding tape at temperatures below 60°F / 15°C

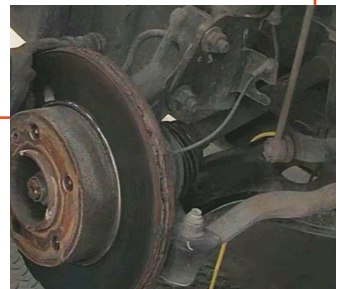

### 3. Warm the bonding tape in your hands and apply it to the appropriate side of the sensor:

- The sensor must always be mounted with the face adjacent to the groove pointing up
- The sensor must always be mounted with the internal domain cable pointing towards the pivot point on the suspension system.

**IMPORTANT.** Please see “Sensor installation positions” on page 23 for further guidance on sensor orientation in specific suspension systems

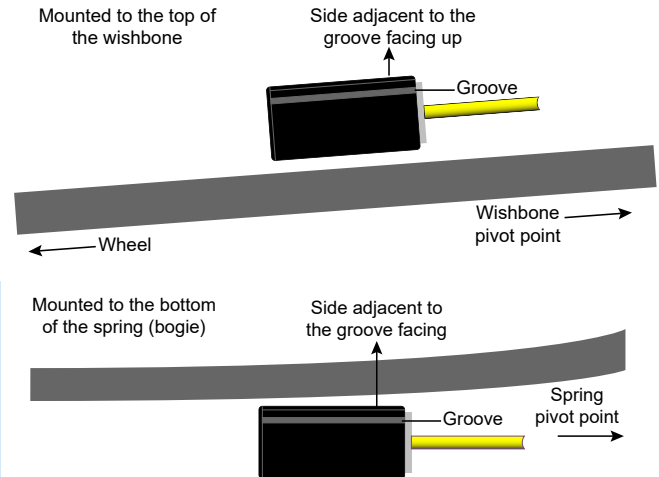

### 4. Mount the sensor to the suspension and clamp in place for a minimum of 10 minutes

### 5. Connect the cable to the ECU

- Ensure that cable to cable connections are well supported
- Avoid running cables on or near sharp objects
- Keep cables away from hot components such as exhausts and engines
- Use cable ties to secure any excess cable to the chassis of the vehicle



**CAUTION.** Use cable protector to protect the cable at positions where it may be exposed to damage

**IMPORTANT.** Ensure that you make a note of the serial number of the sensor and the location on the vehicle where it is installed.

6. Make a note of the serial number of the sensor, the position it is located on the vehicle and the direction it is facing e.g. SN: xxxx, position 1, front left sensor, facing forward

- The internal domain cable is attached to the rear of the transducer. The opposite face is used to indicate which direction the sensor is facing

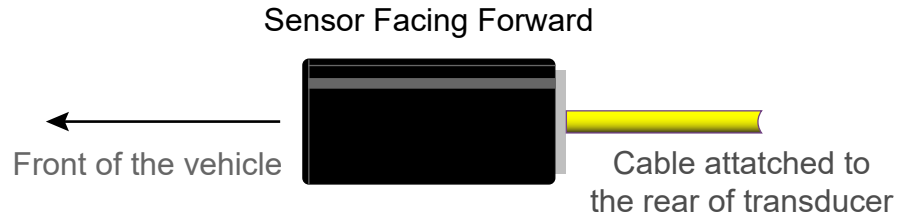

**IMPORTANT.** It is recommended that you use the system configuration table to record this information. See “System configuration table” on page 64

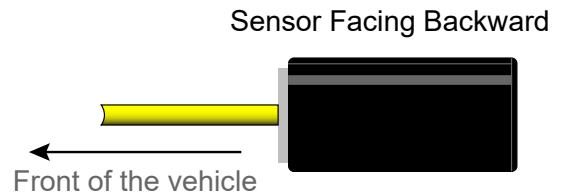

## How to install an air pressure transducer

A single air pressure transducer is used to monitor a single air circuit in an air suspension system.

For example; a single air circuit with one ride height control valve that controls multiple bellows on both sides of the vehicle would require a single air pressure transducer.

If separate air circuits are present, a transducer must be installed on each air circuit.

For example; two air circuits, one with a ride height control valve to control the bellows on the left side and one with a ride height control valve to control the bellows on the right, would require two air pressure transducers, one for the circuit on the left side of the truck and one on the right.

**IMPORTANT.** Ensure that you select the appropriate position for the sensor. Please see “Sensor installation positions” on page 23 for guidance on selecting a position for a sensor

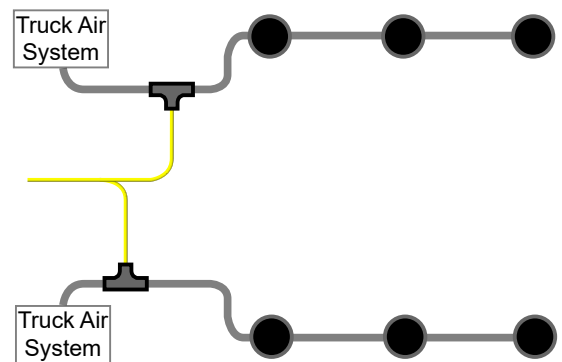
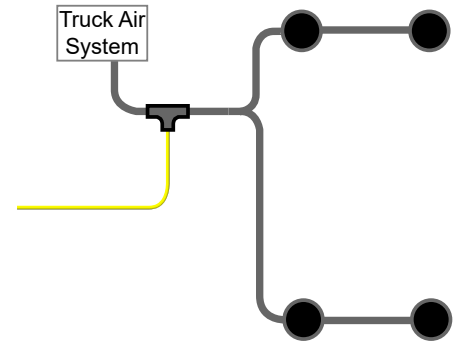

1. Build the air pressure transducer:

- i. Disconnect the fitting from the sensor cable
- ii. Place the washer over the thread. It is recommended that PTFE tape is also applied
- iii. Connect the sensor to the fitting. Use 18 mm and 24 mm spanners to tighten
- iv. Remove the cap from the sensor
- v. Connect the fitting and sensor to the stem of the air pressure T-connector. Push-fit until you hear two clicks to lock the sensor and T-connector together
- vi. Use vernier calipers to measure the outside diameter of the air pipe that the transducer will be fitted to. Select the appropriate size air pipe fittings

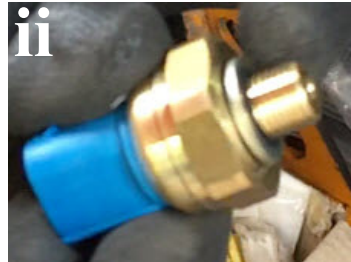

- vii. Connect the air pipe fittings to each side of the tee on the T-connector. Push-fit until you hear two clicks to lock the air pipe fitting and T-connector together

## 2. Depressurise the air suspension systems

**WARNING.** Ensure the air pressure system is fully depressurised to avoid movement in the suspension when the air pipe is cut

## 3. Reconnect the sensor to the cable

**IMPORTANT.** It is recommended that self amalgamating tape is wrapped around the air transducer connector and a little way up the cable to provide protection



## 4. Cut the air pipe at the appropriate position

### 5. Cut approximately 1" of pipe off the cut end of the air pipe

### 6. Clean any dirt from the ends of the air pipe



### 7. Connect the air pipe to each side of the air pressure transducer. Push-fit until you hear one click to lock the pipe into the pipe fittings



## 8. Connect the sensor cable to the ECU

## 9. Secure air pipe, transducer and cable to vehicle

- Use cable ties to support air pipe and sensor cable connections. Secure the connectors to existing cables where possible
- Ensure that cable to cable connections are well supported
- Avoid running cables on or near sharp objects
- Keep cables away from hot components such as exhausts and engines
- Use cable ties to secure any excess cable to the chassis of the vehicle

**CAUTION.** Use cable protector to protect the cable at positions where it may be exposed to damage

**IMPORTANT.** Ensure that you make a note of the serial number of the sensor and the location on the vehicle where it is installed.

## 10. Make a note of the serial number of the sensor and the position it is located on the vehicle, e.g. SN: xxxx, rear left air circuit etc.

**IT** is recommended that you use the system configuration table to record this information. See “System configuration table” on page 64





# System Overview

## VanWeigh Lite<sup>®</sup> Web App Overview

A mobile device must be connected to the ECU via Wifi to receive the information. A web browser on a mobile device is used to display the information in a web app.

**IMPORTANT.** Make sure that the mobile device has a camera and is capable of reading a QR code. You may need to install a QR scanner app. Install the app from the app store if necessary.

**IMPORTANT.** Make sure that the mobile device has a web browser. It is recommended that you use the latest version of Google Chrome on an Android device, or the latest version of Safari on iOS. Install the browser from the app store if necessary.

### Connecting to the web app

Use a mobile device to connect to the web app for the ECU installed on your vehicle.

**IMPORTANT.** Make sure that the mobile device is charged up and powered on.

**IMPORTANT.** Make sure that the wifi for the mobile device is enabled but not connected to another wifi network. You may need to deactivate the 'auto join' wifi feature if this is currently enabled on your mobile device.

**IMPORTANT.** The ECU uses a Wifi signal with a range of approximately 30m (100ft). Make sure you are within Wifi range when you attempt to connect to the web app.

1. Turn the VanWeigh Lite® system on. The system is activated by the vehicle power and may be linked to the ignition.
2. Connect the Wifi on your mobile device to VanWeigh Lite®. There are two methods:
  - Open your camera or QR reader. Scan the SSID QR code for the VanWeigh Lite® Wifi network. Or;
  - Open the Wifi settings on your mobile device. Select the network for the VanWeigh Lite® system. This can be identified by the SSID number found on the barcode label on the ECU. Enter the password for the VanWeigh Lite® network. This is formatted using the six numbers at the end of the SSID number e.g.
    - SSID - VPGAC0BFBxxxxxxVPG
    - Password - VPGxxxxxxvpg
3. Open the VanWeigh Lite® web app. There are two methods:
  - Open your camera or QR reader. Scan the URL QR code for the VanWeigh Lite® web app. Or;
  - Open the web browser on your mobile device. Enter the URL <http://192.168.0.1> to open the web app

**IMPORTANT.** It is recommended that you save the URL as a favourite on the web browser.

**IMPORTANT.** The mobile device will remain connected to the system whilst the WiFi connection is constant. The password does not need to be re-entered unless the WiFi connection is lost, i.e. if the device moves out of range or is powered off.

## Viewing the web app for the first time

The web app will not display any weight measurements until the system has been:

- Configured to reflect the setup of the sensors and ECUs on the vehicle. See “Vehicle configuration” on page 48
- Calibrated to accurately show the weight measurements. Once the configuration is complete, see “How to calibrate the ECU” on page 56

**IMPORTANT.** The web app for the vehicle must be configured to display any values in the appropriate units. See “How to configure the weighing units” on page 47.

The web app will show a message to indicate the current stage of the configuration and calibration process:

- **Config required.** This message indicates that a ECU has been detected but the axles and sensors have not been configured, and the zero and span calibrations have not been done.
- **Zero required.** This message indicates that a ECU has been detected and the axles and sensors have been configured, but the zero and span calibrations have not been done.
- **Span required.** This message indicates that a ECU has been detected, the axles and sensors have been configured and the zero calibration has been done, but the span calibration has not been done.

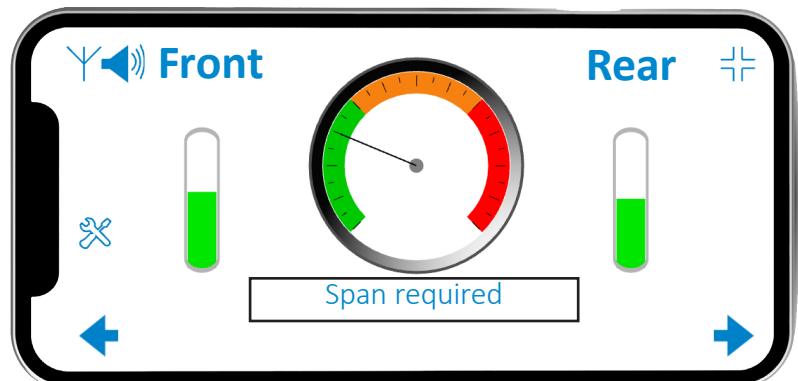
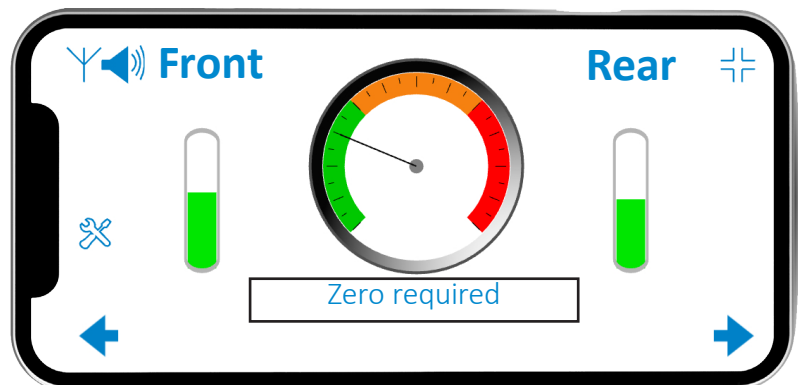
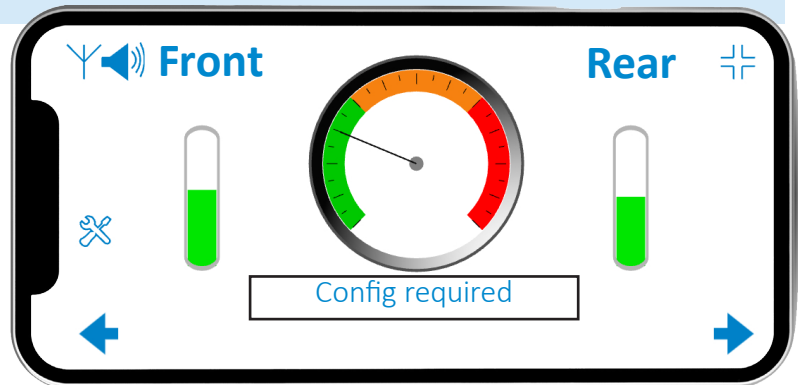

## Web app operation

The web app is displayed on a web browser on a mobile device.

The mobile device must be on and connected to the system. See “Connecting to the web app” on page 36.

The web app can be viewed in landscape or portrait mode:

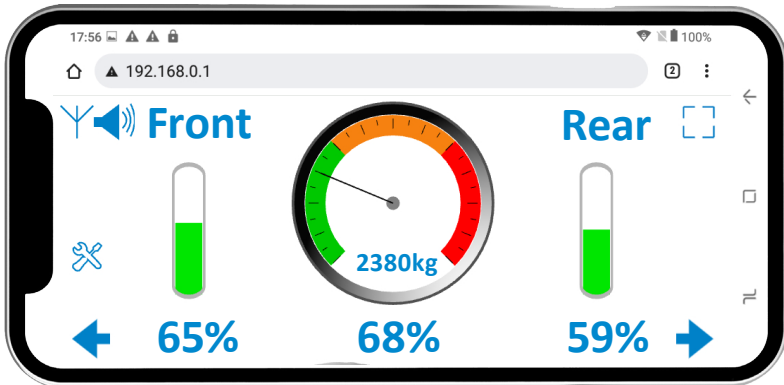

Make sure that the portrait orientation lock on your mobile device is switched off. Rotate the mobile device to switch between landscape and portrait view.

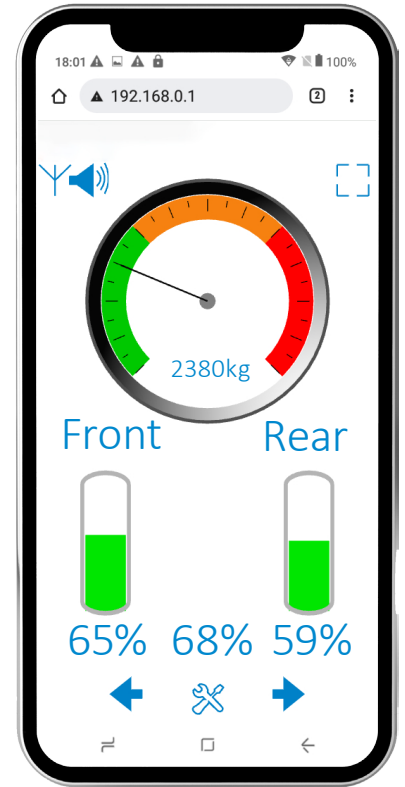

## Home Page

The home page is the first page that is displayed when the web app is switched on. This shows:

- The total weight of the vehicle and its percentage of the maximum weight that can be applied.
- The weight of the vehicle that is currently over the front axle and its percentage of the maximum weight that can be applied to that axle.
- The weight of the vehicle that is currently over the rear axle and its percentage of the maximum weight that can be applied to that axle.

Tap the left or right arrows for alternative displays of the information. You can select the default view in the Set up menu. See “Set Up menu” on page 42

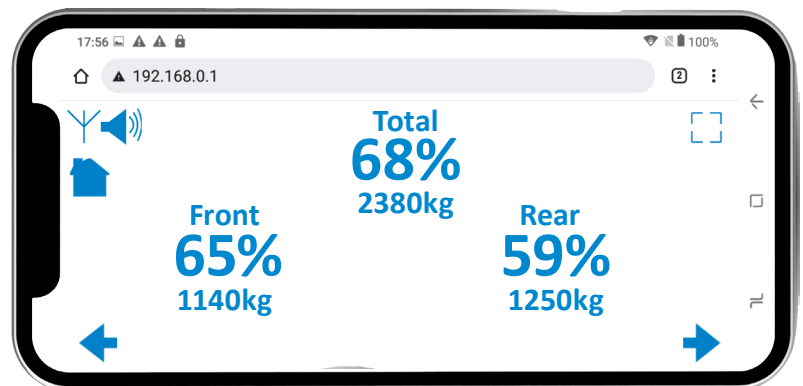
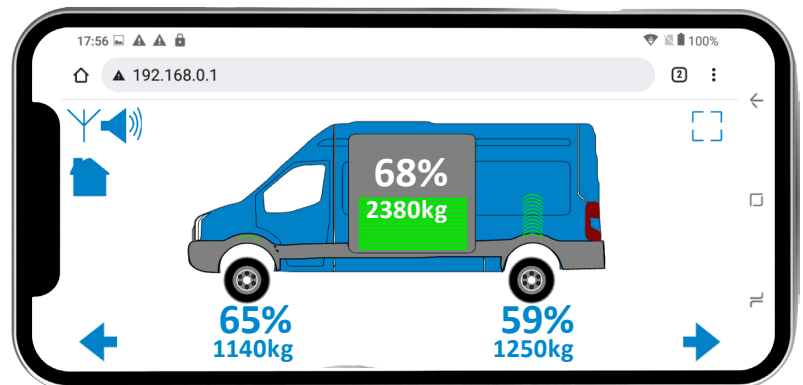
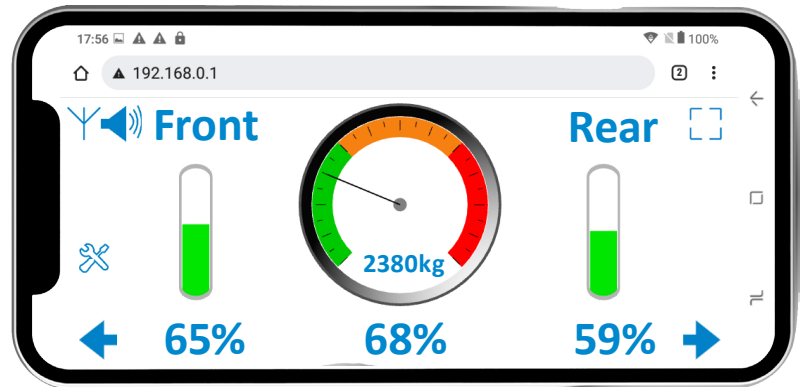

## How to navigate the web app

Use the touch screen to navigate the web app and access the menus and edit the settings.

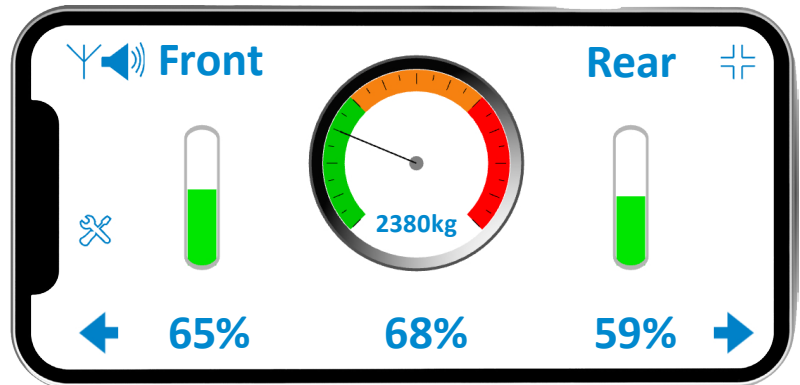

Additional icons are used to display information and interact with the web app:



Connection icon. This indicates that the device is connected to the ECU.



Connection lost icon. This indicates that the connection to the ECU has been lost.



Sound on icon. Tap to mute the app audio.



Muted icon. Tap to unmute the app audio.



Expand icon. Tap to expand the view to full screen.



Collapse icon. Tap to shrink the view to fit the browser window.



Home Icon. Tap to return to the home page.



Settings icon. Only available on the default homepage. Tap to open the set up menu.



Back icon. Tap to go back to the previous page.





Forward icon. Tap to go to the next page.

## Set Up menu

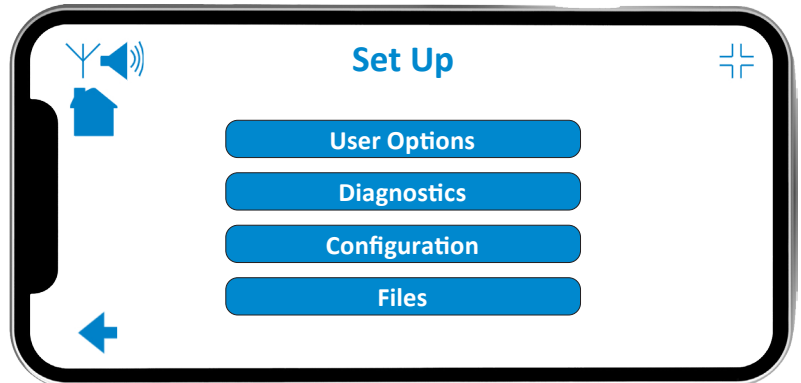
Tap the settings icon to open the set up menu:



There are additional options in the menus:

-  Sub menu button. Tap to open the submenu.
-  Sub menu button, currently unavailable.
- Numerical input field. Tap to edit.
- Option list field. Tap to select an option.



## Editing Values

There are two methods for editing the values in the system. The appropriate method is displayed when an editable value is tapped.

A list is displayed when an option list field is tapped:

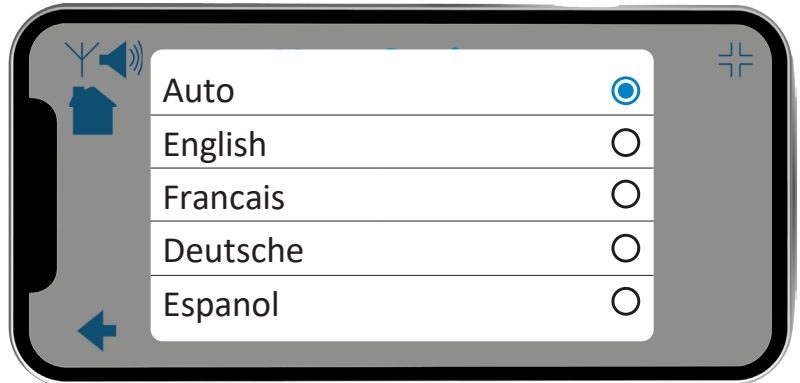

Tap an option to select it.

A keypad is displayed when a numerical input field is tapped:

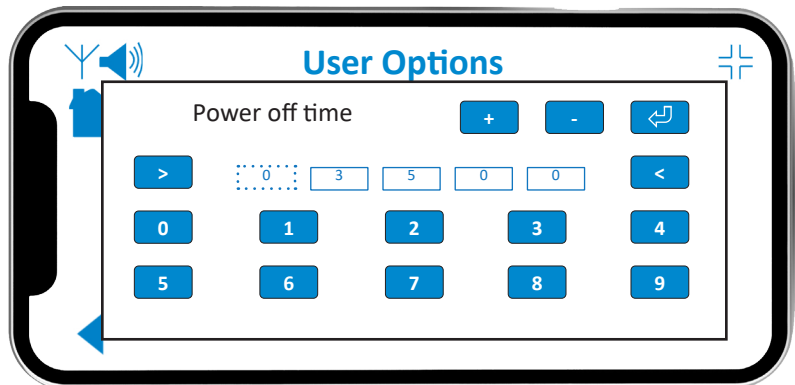

Tap an arrow to select the number you want to change. Tap a number or the +/- icon to change the numerical value. Tap the return button to set the value.

## How to configure the user options

From the home page, go to: Set Up > User Options:

- Power off time. The system will power off when power off timer has elapsed. The web app will display a message to confirm that the system has powered off until communication with the ECU is restored.
  - Language. This is the display language for the web app.
  - Homepage. This is the default homepage view that is displayed when the web app is on.
  - SW Version. This indicates the current software version of the web app.
1. Tap the Power Off Time field.
  2. Input the number of minutes that should pass before the app powers off.
  3. Tap the Language field. An option list is displayed.
  4. Tap the Language value to select the language for the display.
  5. Tap the back icon.

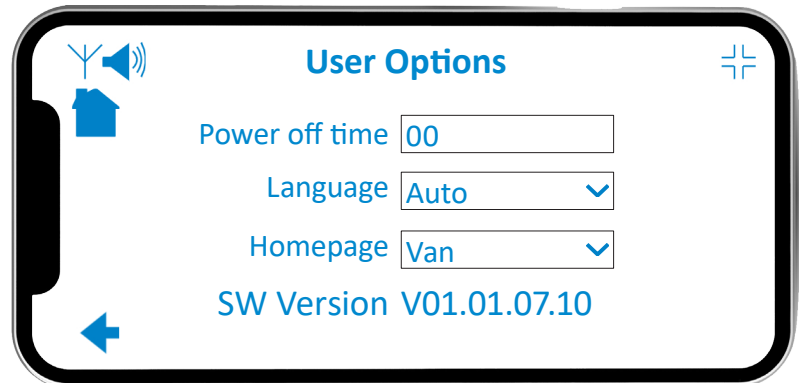

**IMPORTANT.** If the settings have changes a message box will appear saying 'Save changes?'. Tap Yes to save.

# Configuration

## The configuration menu

Tap the settings icon on the home page to open the set up menu then tap configuration to open the configuration submenu:

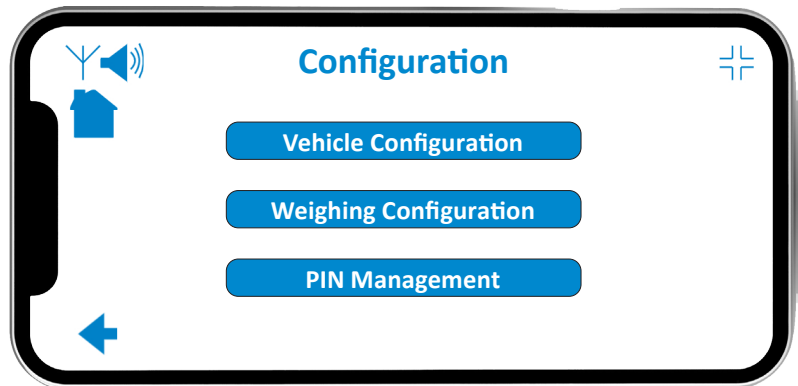

There are three more submenus in the configuration menu:

- **Vehicle Configuration.** Use this menu to input the vehicle configuration into the VanWeigh Lite® system. This is a step by step process that allows you to configure the ECU and alarms and finally calibrate the system. The vehicle will start to display weight measurements when the calibration is complete.
- **Weighing Configuration.** Use this menu to configure the weighing units and how the weight values are displayed.
- **PIN Management.** Use this menu to edit the PIN numbers that allow access to the VanWeigh Lite® system.

**IMPORTANT.** The weighing units are set to kg by default. Change this to the correct unit before configuring and calibrating the display unit, if required. See “How to configure the weighing units” on page 47

## How to configure the weighing units

It is recommended that you configure the weighing units before configuring the vehicle. From the home page, go to: Set Up > Configuration > Weighing Configuration:

1. Tap the Weighing Units field. An options list is displayed.
2. Select the units to display in the web app.
3. Tap the Count By field. An options list is displayed.
4. Select the value that the weight measurements are rounded to when they are displayed in the app.

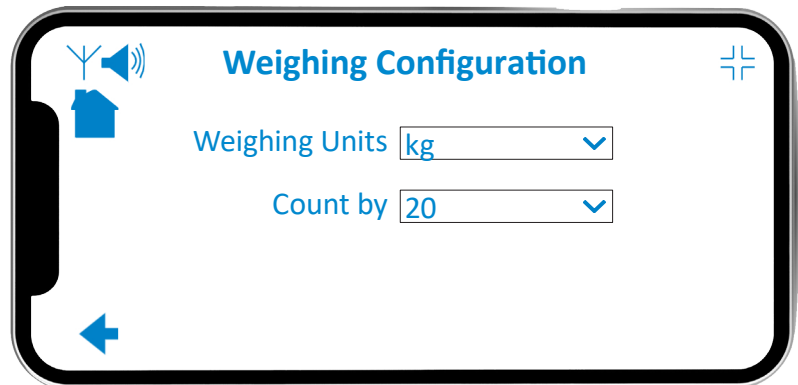

**IMPORTANT.** It is recommended that the count by value is set to 20 kg for minimum stability

5. Tap the back icon.

**IMPORTANT.** If the settings have changes a message box will appear saying 'Save changes?'. Tap Yes to save.

## Vehicle configuration

The vehicle configuration is a step by step process that allows you to configure the ECU, alarms and stability options, and finally calibrate the system. From the home page, go to: Set Up > Configuration > Vehicle Configuration:

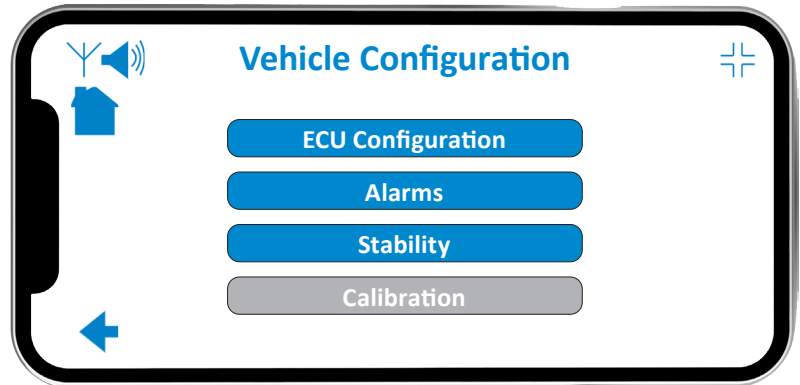

The vehicle configuration menu displays the configuration settings for the ECU on the vehicle.

**IMPORTANT.** The Calibration menu is unavailable until the ECU Configuration is complete and saved.

## How to configure the ECU

The ECU is configured in the vehicle configuration menu. From the home page, go to: Set Up > Configuration > Vehicle Configuration > ECU Configuration.

The display represents the ECU and sensors installed on the vehicle.

The sensor numbers are automatically populated and match the positions they are installed on the vehicle.

Each option box should be set to match the way the vehicle is configured.

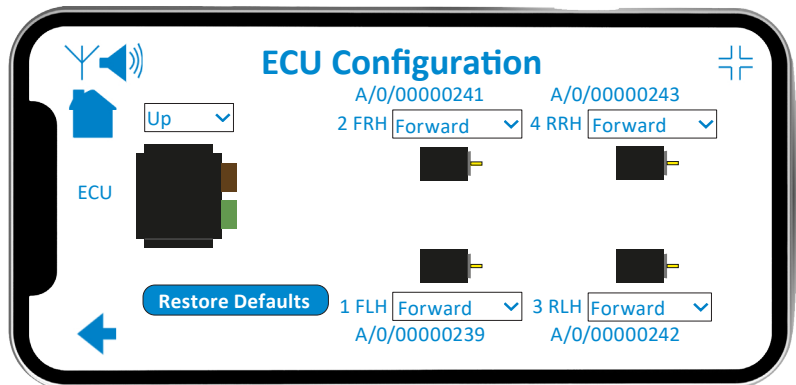

1. Tap the ECU field. The ECU orientation options are displayed.
2. Select the orientation of the ECU. Choose from Up, Down, Left or Right.

**IMPORTANT.** The ECU orientation is determined by the direction the top face of the box is facing. For example; Up, down, left side or right side of the vehicle. Please see “How to install the ECU” on page 20 for further details.

3. Tap a sensor field. The sensor orientation options are displayed.

**IMPORTANT.** The sensor field is deactivated when an air pressure transducer is installed in that position. Air pressure transducers are represented by a black circle graphic and do not require an orientation setting.

4. Select the orientation of the sensor. Choose from Forwards, Backwards, or N/A.

- Select Forwards if the sensor is facing the front of the vehicle
- Select Backwards if the sensor is facing the rear of the vehicle
- Select N/A when the sensor is on a strut

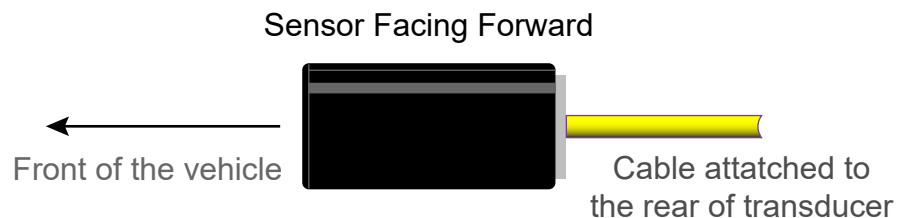

5. Repeat steps 3 and 4 to set the orientation for each sensor.

**IMPORTANT.** The position number is the position of the sensor on the vehicle. Number 1 (FLH) is the sensor on the front axle, this is the sensor on the left side of the axle, 2 (FRH) is the sensor on the right. 3 (RLH) is the sensor on the left side of the second axle etc. See “Sensor installation positions” on page 23 for more information.

6. Tap the back icon.

**IMPORTANT.** If the settings have changed a message box will appear saying ‘Save changes?’. Tap Yes to save.



## How to configure the alarms

The alarms are configured in the vehicle configuration menu. From the home page, go to: Set Up > Configuration > Vehicle Configuration > Alarms.



**IMPORTANT.** Obtain the maximum allowable gross and axle weights from the vehicle data plate

Each alarm should be enabled and configured as required for the vehicle.

- Tap Disabled on an alarm to enable it. The setting will change to show that the alarm is Enabled.
- Tap Enabled on an alarm to disable it. The setting will change to show that the alarm is Disabled.

**IMPORTANT.** Alarm figures must be input to ensure accurate percentage values are displayed on the home screens.

1. Tap the weight value for an alarm. A pop up menu is displayed:

The current weight value is displayed in the boxes in the middle of the pop up.

2. Set the value that will trigger the alarm when the payload exceeds it.
  - The Gross alarm should be set to the maximum allowable weight for the vehicle.
  - The Axle 1 alarm should be set to the maximum allowable weight for the front axle.
  - The Axle 2 alarm should be set to the maximum allowable weight for the rear axle.
3. Tap Done.

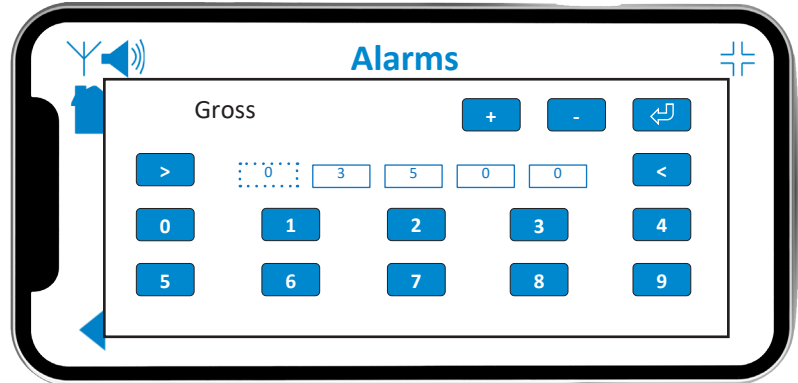

**IMPORTANT.** If the settings have changes a message box will appear saying ‘Save changes?’. Tap Yes to save. Tap the Save icon

4. Repeat steps 2 and 3 to configure each alarm as required.
5. Tap the back icon.

## How to configure stability

The stability is configured in the vehicle configuration menu. From the home page, go to: Set Up > Configuration > Vehicle Configuration > Stability.

The stability options control how the data displayed on the homepage is refreshed.

1. Tap the Jitter Filter value to set the jitter filter for the display.
  - The Jitter Filter is the weight refresh rate for the homepage. Use this to reduce fluctuation in displayed weights. The higher the number the slower the refresh rate.

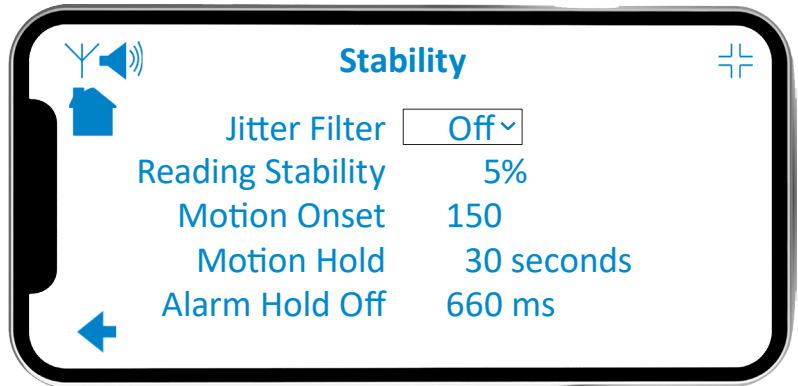

2. Set the jitter filter. Choose from Off, 1, 2 or 3.

**IMPORTANT.** The jitter filter is only required if the displayed weights fluctuate on the display unit when the vehicle is stationary. Set to off to turn the jitter filter off. Set to 1,2, or 3 to apply a stabilising filter to the data that is displayed on the home page. This should be set to the required level after the calibration is complete.

3. Tap the Reading Stability value to edit it. A pop up menu is displayed:

- The system will display a message when it detects that the displayed weight is unstable. Reading stability is the percentage of the currently displayed weight required to trigger the message. The higher the percentage the lower the possibility that motion detected message is displayed.

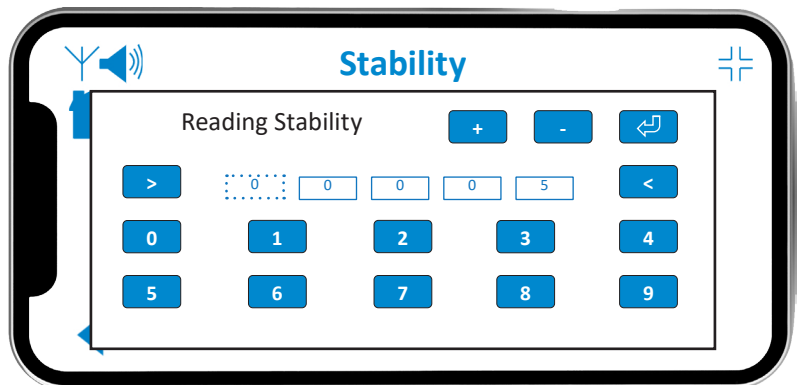

4. Set the value that will trigger the motion detected message.

5. Tap the Motion Onset value to edit it. A pop up menu is displayed:

- Motion Onset determines if the vehicle is in motion. When the vehicle is in motion all active alarms are disabled and a motion detected message is displayed. The lower the figure the more sensitive the motion detection is.

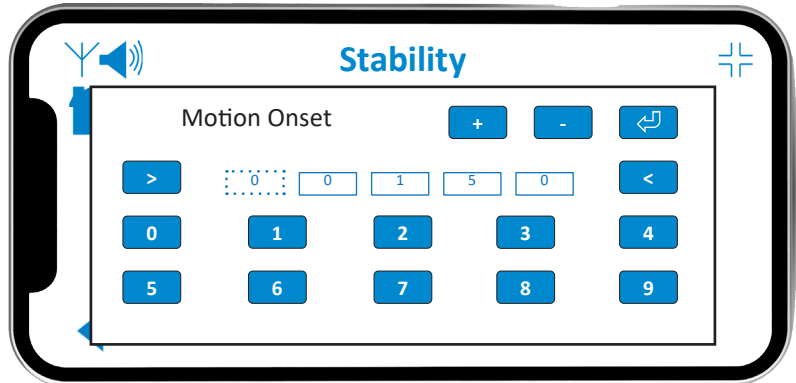

6. Set the value for the motion onset sensitivity.

7. Tap the Motion Hold value to edit it. A pop up menu is displayed:

- Motion Hold sets a delay between when the system detects that the vehicle is no longer in motion and when the alarms are re-enabled.

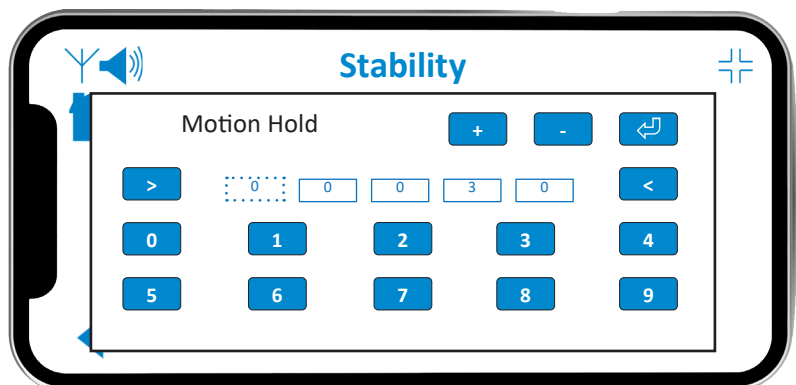

8. Set the number of seconds for the motion hold delay.

9. Tap the Alarm Hold Off value to edit it. A pop up menu is displayed:

- Alarm Hold Off sets a delay between when the alarms are enabled and when the alarm sounder is activated if the system detects a payload that exceeds the values set for the Gross alarm or either Axle alarm.

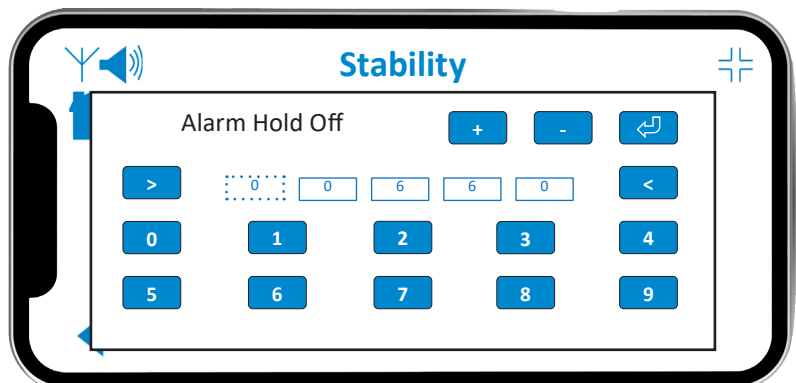

10. Set the number of milliseconds for the alarm hold off delay.

11. Tap the back icon.

**IMPORTANT.** If the settings have changed a message box will appear saying 'Save changes?'. Tap Yes to save.

## Weighing the Vehicle

Once the VanWeigh Lite® system has been configured, it must be calibrated. This requires multiple weight measurements of the wheels on the vehicle.

**IMPORTANT.** Ensure that you know the gross vehicle weight (GVW) before you calibrate the system

Two sets of vehicle measurements must be taken:

- Zero weights. This is the weight measurement of each wheel when the vehicle is empty
- Span weights. This is the weight measurements of each wheel when the total weight of the vehicle is as close to GVW as possible

**IMPORTANT.** The zero weights calibration data should be entered into the display unit when the vehicle is empty and the zero weight measurements are taken. The span calibration data should be entered into the display unit when the vehicle is at GVW and the span weight measurements are taken. See “How to calibrate the ECU” on page 56

Weigh pads:

The weight measurements can be taken by using weigh pads.

**IMPORTANT.** Vehicle weighing should be performed on a flat, level surface, in calm weather conditions. If possible, weigh the vehicle indoors.



Use one pair of weigh pads per axle.  
Record the weight values for each wheel.

Weigh bridge:

It may not be possible to capture individual wheel weights when using a weigh bridge or axle weigh bridge.

Make sure both axles are on the same plane. Weigh each axle and divide the recorded weight by two to obtain values for each wheel.

## How to calibrate the ECU

Use the mobile device to calibrate the VanWeigh Lite® system after it has been configured and the vehicle has been weighed.

**IMPORTANT.** It is recommended that the system is powered on for at least 10 minutes to allow the system to acclimate before the calibration process is performed.

From the home page, go to: Set Up > Configuration > Vehicle Configuration > Calibration.

Two calculations are required to calibrate the ECU:

- Zero all wheels. This is a calculation based on the weight measurements of each wheel when the vehicle is empty. This calculation should be performed first.
- Span all wheels. This is a calculation based on the weight measurements of each wheel when the payload on the vehicle is at its maximum allowable weight. This calculation should be performed after the zero all wheels calculation is complete.

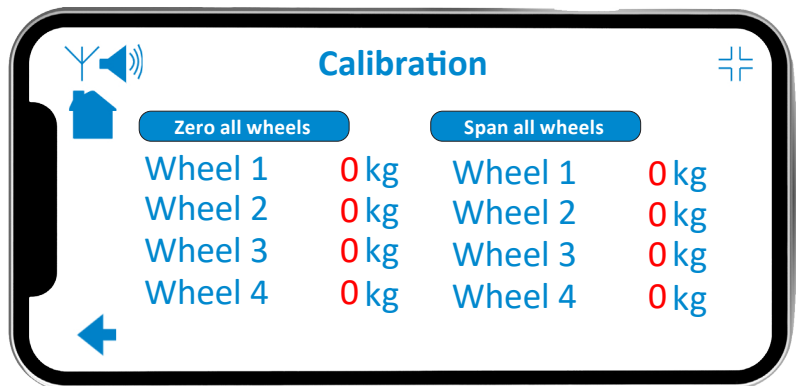

**IMPORTANT.** Make sure the vehicle is empty before starting the zero calibration

1. Tap the weight value of a Wheel in the Zero all wheels list. A pop up menu is displayed:
2. Set the zero weight value of the Wheel.

- Wheel 1 corresponds to position 1 (FLH) in the ECU configuration page.
- Wheel 2 corresponds to position 2 (FRH) in the ECU configuration page.
- Wheel 3 corresponds to position 3 (RLH) in the ECU configuration page.
- Wheel 4 corresponds to position 4 (RRH) in the ECU configuration page.

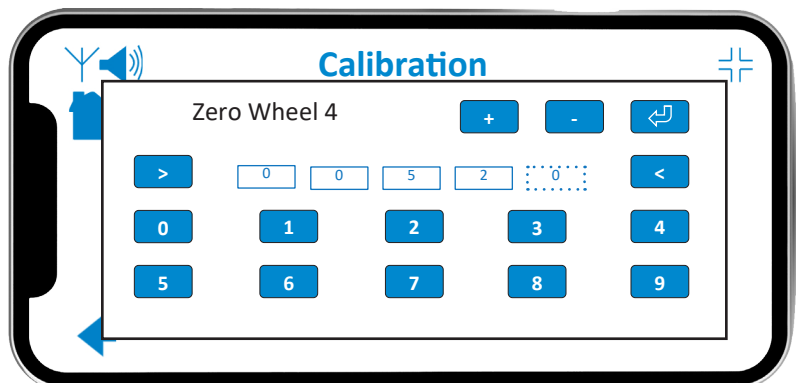

3. Tap Return.
4. Repeat steps 2 and 3 to input the zero weight values for each wheel in the Zero all wheels list.
5. Tap Zero all wheels. A confirmation message is displayed.
6. Tap Yes to perform the zero all wheel calculation. A message is displayed to indicate that the calibration is being processed. The Zero figures for each wheel will turn green when the calibration is complete.

**IMPORTANT.** Make sure the vehicle is at GVW before starting the span calibration

7. Tap the weight value of a Wheel in the Span all wheels list.
8. Set the span weight value of the Wheel.
9. Tap Return.
10. Repeat steps 7 and 8 to input the span weight values for each wheel in the Span all wheels list.
11. Tap Span all wheels. A confirmation message is displayed.
12. Tap Yes to perform the span all wheel calculation. A message is displayed to indicate that the calibration is being processed. The Span figures for each wheel will turn green when the calibration is complete.
13. Tap the home icon
14. Check that the values on the display match the span weight measurements

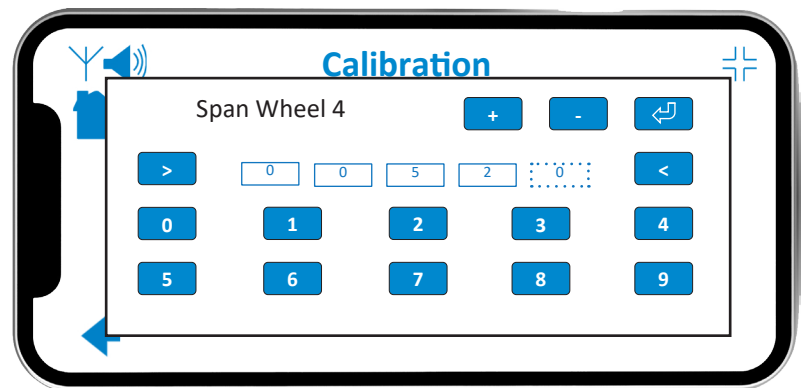

**IMPORTANT.** If using a weigh bridge or axle weigh bridge it may not be possible to capture individual wheel weights. Make sure both axles are on the same plane. Weigh each axle and divide the recorded weight by two to obtain values for each wheel.

## How to configure the PIN Numbers

The PIN numbers are configured in the vehicle configuration menu. From the home page, go to: Set Up > Configuration > PIN Management.

There are two PIN Numbers:

- The Fleet Manager PIN allows access to non critical system settings, including the Weighing Configuration.
- The Engineer PIN allows full access to the system settings, including Vehicle Configuration and Calibration.
- Use the Restore Defaults option to restore both PIN numbers to the factory default PINs.

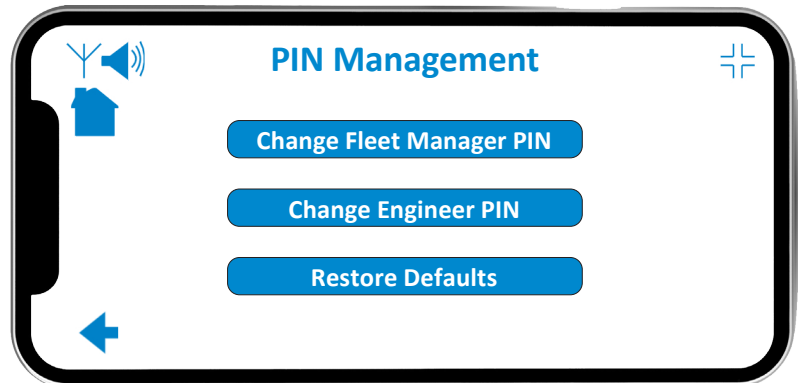

**IMPORTANT.** PIN Management is only available when you log in with the Fleet Manager or Engineer PIN. Log in with the Fleet Manager PIN to access the Change Fleet Manager PIN only. Log in with the Engineer PIN to access both PIN numbers and the Restore Defaults option.

1. Tap a Change PIN option to change the PIN. A pop up menu is displayed:
2. Type the New PIN.
3. Type the same number in the Confirm PIN field to save the new PIN.

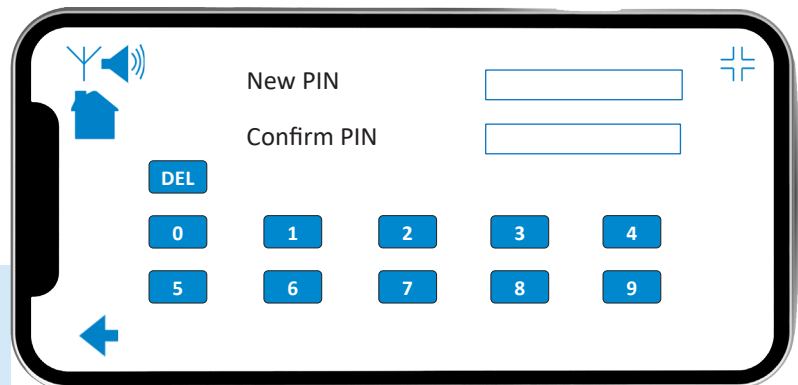

**IMPORTANT.** Contact VPG service for access if the Engineer PIN has been lost.



# Diagnosics

## The diagnostics menu

The diagnostics menu is a series of read only pages that reflect the configuration of the ECU. From the home page, go to: Set Up > Diagnostics:

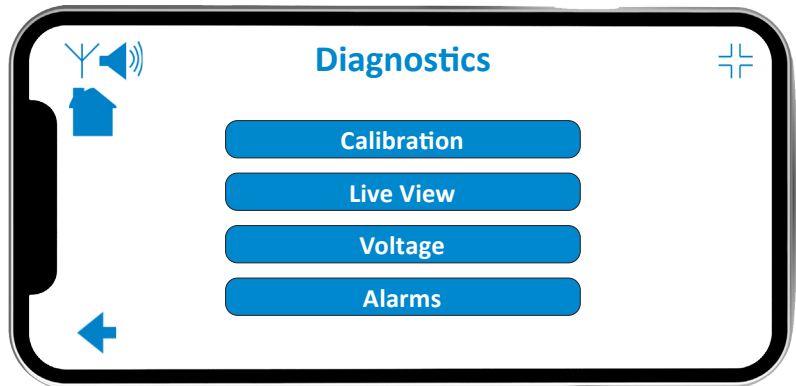

There are four sub menus in the diagnostics page:

- Calibration. Use this menu to view information about the calibration parameters for the ECU:

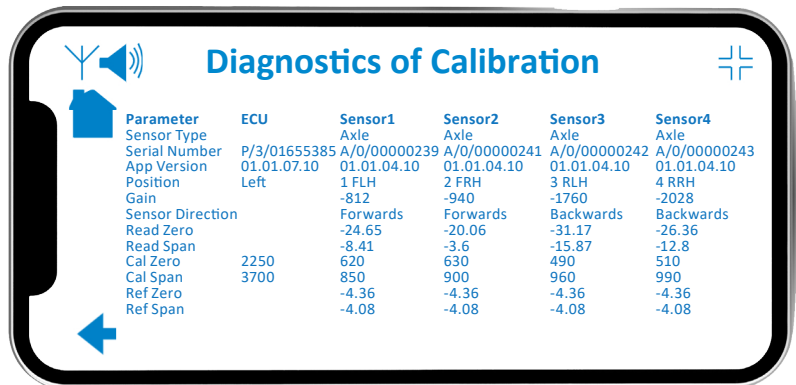

- Live View. Use this menu to view live information about the sensors and ECU:

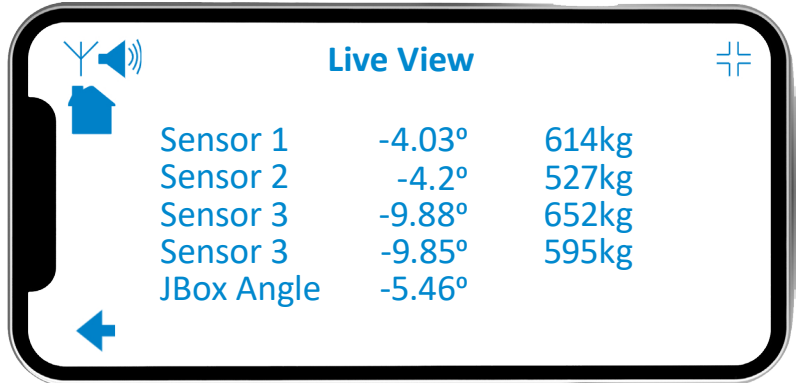

**IMPORTANT.** Air pressure transducers presented as mV readings

- Voltage. Use this menu to view voltage information about the ECU:

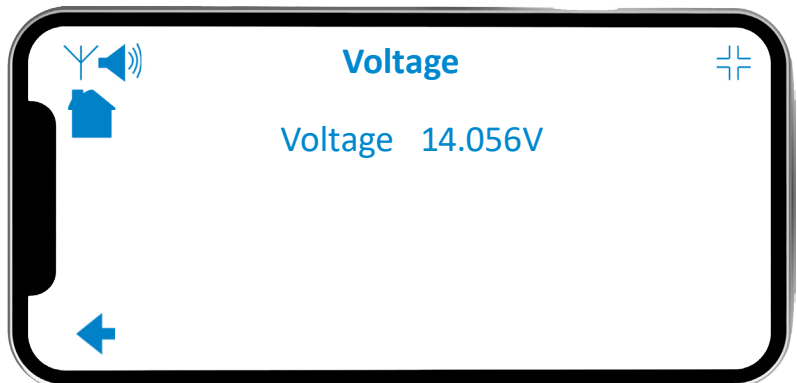

- Alarms. Use this menu to view the alarm configuration:





# Appendix A

## System configuration table

ECU: \_\_\_\_\_

Orientation: \_\_\_\_\_

Axle	Sensors									
	Vehicle Left Side					Vehicle Right Side				
Axle No.	Sensor Type	Orientation	Serial No.	Zero Weight	Span Weight	Sensor Type	Orientation	Serial No.	Zero Weight	Span Weight
1										
2										

It is recommended that you photocopy this table and use it to record the details of the sensors on your vehicle and record the zero and span weights for each wheel.

# Appendix B

## VanWeigh Lite® Specification

Axle overload protection for two axle light commercial vehicles.

PARAMETRS	MINIMUM	TYPICAL	MAXIMUM	UNIT
<b>SYSTEM</b>				
Accuracy	Better than 2.5%			90 - 110% of Full scale
Capacity (GVW)	Any two axle vehicle			
Operating voltage	9		36	VDC (US and RoW)
Operating temperature	-40		70	°C
	-40		158	°F
Current at 24V/12V (4 x transducers)			104/182	mA
Current standby at 24V/12V			2/1	mA
Weighing modes	Gross, Axles			
<b>WI-FI ENABLED DEVICE</b>				
On screen display				kg or lb
Overload alarm-audible	Yes (depending on Wi-Fi enabled device)			
Alarm output level	Wi-Fi enabled device dependent			
Password protection	4 digits, engineer and fleet manager PIN			
<b>TRANSDUCERS</b>				
Transducer types	Up to 4 axle/air transducers			
<b>ACCESSORIES AND OPTIONS</b>				
Wi-Fi enabled device (with hard wired charger cable)	Yes			
Adjustable bracket	Yes			
Printer capability	No			



# Appendix C



## Warning and Status Messages

WARNING / MESSAGE	DESCRIPTION
ECU Powering down in xx seconds	Vehicle ignition has been removed and power off timer is active. System will power down once timer elapses.
Power off cancelled	<p>Pressing “Cancel Power off”, during the ECU Powering down in xx seconds window, will enable the system to remain on if a battery connection is present.</p> <ul style="list-style-type: none"> <li>• Ensure the vehicle ignition is turned on then off before leaving the vehicle to preserve vehicle battery.</li> </ul>
ECU has powered off	The power off timer has elapsed and the system has shut down.
Connection to ECU lost	<p>Communication lost to VanWeigh Lite® ECU.</p> <ul style="list-style-type: none"> <li>• Check WI-FI connect on device.</li> <li>• Check vehicle ignition is on.</li> <li>• Check connections.</li> </ul>
~ Motion Detected	<p>The reported weights are unstable</p> <ul style="list-style-type: none"> <li>• Vehicle is in motion</li> <li>• Vehicle is being loaded/unloaded</li> </ul>
Incline too great!	<p>System ECU has detected an incline greater than <math>\pm 5^\circ</math>.</p> <ul style="list-style-type: none"> <li>• Weights may not be accurate</li> </ul>
Invalid Pin!	<p>Wrong PIN number used.</p> <ul style="list-style-type: none"> <li>• Input correct PIN</li> <li>• Contact approved agent to access system.</li> </ul>
Calibrating, please wait	<p>System is saving the calibration settings to the ECU.</p> <p>Important: Do not power down the system when this message is displayed.</p>

WARNING / MESSAGE	DESCRIPTION
Update Config Save New Setting?	The system is asking if the new settings need to be saved. Tap Yes to save or No to revert to previous settings.
Sensor X Missing	<p>The digit "X" represents the position of the missing axle transducer.</p> <ul style="list-style-type: none"> <li>• Check connections</li> <li>• Contact approved agent</li> </ul>
<p>System Error!</p> <p>Calibration Delta Low on Sensor X</p> <p>Recalibration recommended</p>	<p>No physical movement has been detected between the zero and span calibration process. The digit "X" represents the position of the axle transducer.</p> <ul style="list-style-type: none"> <li>• Vehicle must be loaded to GVW at span calibration</li> <li>• Check sensor is attached to suspension component.</li> </ul>
<p>System Error!</p> <p>Sensor Calibration Opposite Delta</p> <p>Recalibration recommended</p>	<p>Indicates that the axle transducers have physically moved in opposite directions during the calibration process. For example the sensor in position 1 travelled in a positive direction and the sensor in position 2 travelled in a negative direction.</p> <ul style="list-style-type: none"> <li>• Check physical sensor directions are correct.</li> <li>• Vehicle must be loaded to GVW at span calibration.</li> <li>• Check sensor is attached to suspension component.</li> </ul>
Config Required	This message indicates that an ECU has been detected but the system has not been configured or calibrated.
Zero Required	This message indicates that an ECU has been detected, the system has been configured, but the zero calibration has not been done.

WARNING / MESSAGE	DESCRIPTION
Span Required	This message indicates that an ECU has been detected, the system has been configured, but the span calibration has not been done.
Save changes?	A prompt to allow the operator/installer to save any changes to the system that have been made. <ul style="list-style-type: none"><li>• Tap Yes to save.</li><li>• Tap No to return to previous settings screen.</li></ul>

## Alarm Icons

ICON	DESCRIPTION
	<p>An overload event is active and the audible alarm is active. Tap icon to mute.</p>
	<p>An overload event is active and the audible alarm is muted. Tap icon to activate sounder.</p>

# VPG ONBOARD WEIGHING



## Contact

**VPG System UK Ltd**

**Airedale House,**

**Canal Road**

**Bradford BD2 1AG**

**PH: +44 (0) 1274 771177**

**FAX: +44 (0) 1274 781178**

**E-MAIL: [obw.uk@vpgsensors.com](mailto:obw.uk@vpgsensors.com)**

**VPG Onboard Weighing**

**5920 S 194th Street**

**Kent, WA 98032**

**USA**

**PH: Toll Free 800-237-0022**

**or: +1-919-219-6471**

**E-MAIL: [obw.us@vpgsensors.com](mailto:obw.us@vpgsensors.com)**

[vpgonboard.com](http://vpgonboard.com)

**Disclaimer:** The document and the products described herein are subject to change from time to time without notice and are also subject to specific disclaimers. Please visit <https://vpgsensors.com/disclaimer> for more information.